



CLASS II

# SERVICE INSTRUCTIONS

CLASS II

19, 23, 24

No. 0892  
ATA Code 37-00

**SUBJECT:** VACUUM SYSTEM - RELOCATION OF AIR FILTER

**EFFECTIVITY:** BEEHCRAFT B19, serials MB-481 through MB-520;  
B19 Sport 150, serials MB-521 through MB-818;  
C23, serials M-1285 through M-1361;  
C23 Sundowner 180, serials M-1362 through M-1883;  
A24, serials MA-364 through MA-368;  
A24R, serials MC-2 through MC-95;  
A24R, B24R and C24R Sierra 200, serials MC-96 through MC-453.

**REASON:** To provide a new location for the vacuum pump air filter and improve its reliability should a leak occur at the windshield or firewall.

**COMPLIANCE:** At the owner's discretion, however, Beech Aircraft Corporation recommends this modification be accomplished at the next scheduled inspection.

**DESCRIPTION:** The vacuum pump air filter is relocated.

**APPROVAL:** FAA Approved - DOA CE-2.

**MANPOWER:** The following information is for planning purposes only:  
  
Estimated man-hours; 2 hours.  
Suggested number of men: 2 men.

**MATERIAL:** None.

**WARRANTY:** BEEHCRAFT warranty on a new airplane is 180 days from delivery or 180 days from the date noted on the Owner Warranty Card. Warranty credit for labor to the extent noted under MANPOWER will be allowed for BEEHCRAFTS within warranty at the time these Service Instructions are released.  
  
All warranty reimbursements are handled through franchised BEEHCRAFT Outlets. Owners and operators may arrange with these outlets to perform the work and submit the standard Beech Aircraft Corporation warranty claim form to the Commercial Service Department, Beech Aircraft Corporation, Wichita, Kansas, 67201.

**SPECIAL TOOLS:** None.

AW-1098  
377 II

1 of 3

Beech Aircraft Corporation issues service information for the benefit of owners and fixed base operators in the form of three classes of Service Instructions. CLASS I (Red Border) are changes, inspections, and modifications that could affect safety. The factory considers compliance mandatory. CLASS II (Green Border) covers changes, modifications, improvements or inspections the factory feels will benefit the owner and although highly recommended, they are not considered mandatory compliance, unless specified at the time of issuance. Class I and II are mailed to:

- (a) BEEHCRAFT Aero or Aviation Centers and International Distributors and Dealers.
- (b) Owners of record on the FAA Registration list and the

BEEHCRAFT International Owner Notification Service List.  
(c) Those having a publications subscription.

CLASS III (No Border) covers changes which are optional, maintenance aids, product improvement kits and miscellaneous service information. Compliance is at the owner or operator's prerogative. Copies of Class III are distributed per a and c above. Information on Owner Notification Service or Subscriptions can be obtained through any BEEHCRAFT Aero or Aviation Center, International Distributor and Dealer, or the Factory. As Service Instructions are issued, temporary notation in the index should be made until the index is revised. Warranty will be allowed only when specifically defined in the Service Instructions and in accordance with Beech Warranty Policy.

98-34238D



**Service Instructions No. 0892**

**WEIGHT AND BALANCE:** None.

**REFERENCES:** None.

**PUBLICATIONS AFFECTED:** None.

**ACCOMPLISHMENT  
INSTRUCTIONS:**

These Service Instructions may be accomplished in the following manner:

1. Remove the glareshield from the top of the instrument panel.
2. Drill two .125/.133-inch diameter holes in the 169-400005-809 angle as shown in the illustrations.

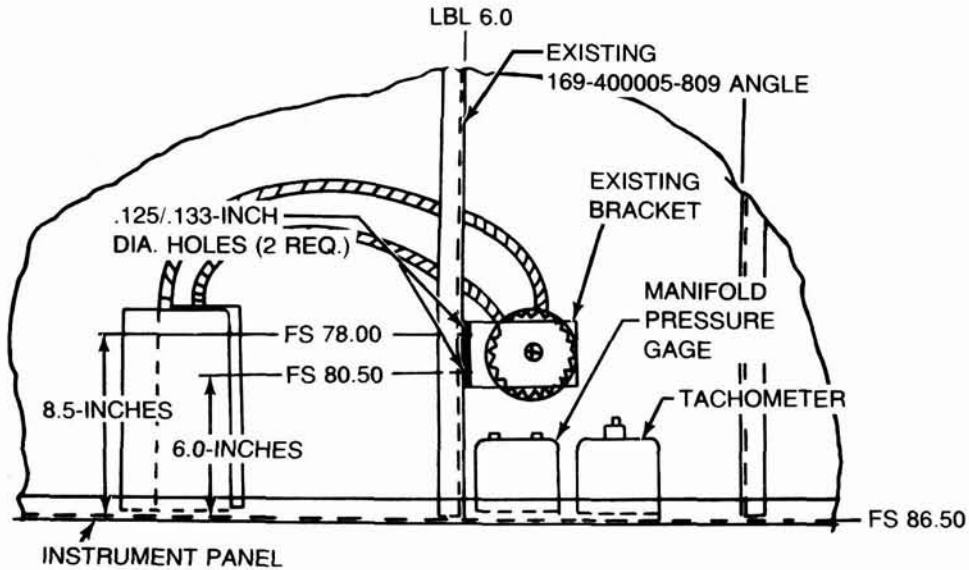

**View A. View Looking Down.**

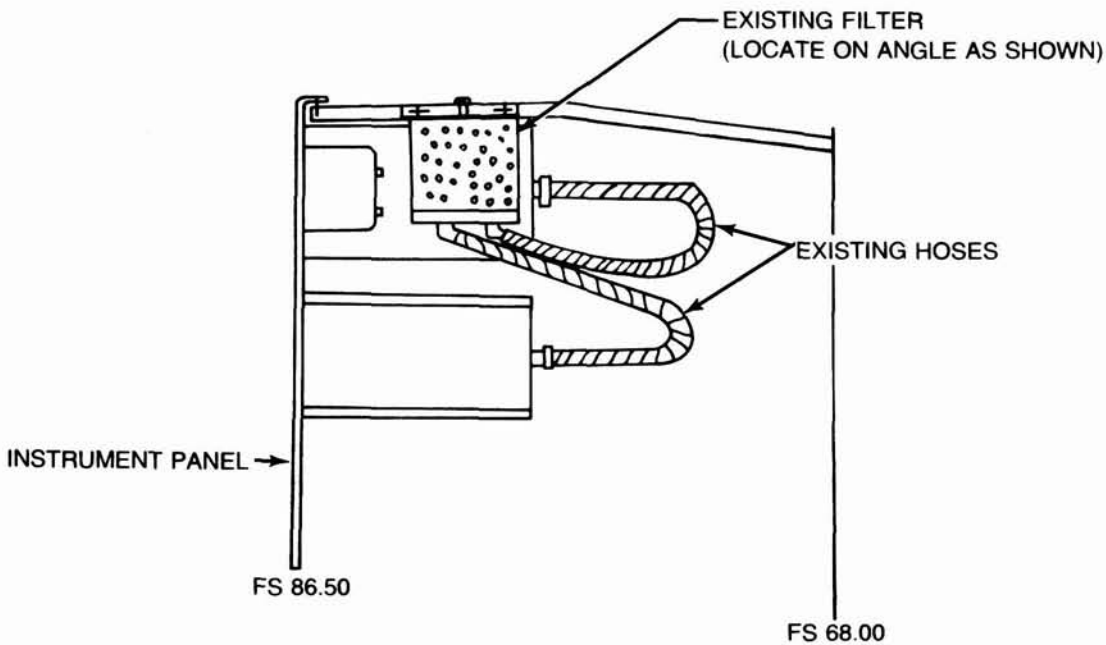

**View B. View Looking Outboard From C/L to LH Side.**

3. Remove the air filter and bracket from the engine firewall.
  4. Using the existing attaching hardware, install the air filter and bracket on the 169-400005-809 angle as shown in the illustrations.
  5. Check for sharp bends or kinks in the vacuum hoses and adjust the hoses as necessary to assure that sharp bends or kinks do not occur.
  6. Reinstall the glareshield.
- 

**RECORD COMPLIANCE:**

Upon completion of these Service Instructions, make an appropriate maintenance record entry.